



4-68 型 离心通风机 Model 4-68 Centrifugal Ventilato



4-68 型离心通风机可作为一般工厂及大型建筑物的室内通风换气用,既可以用来输入气体,也可以用来输出气体。输送空气和其他不自燃的、对人体无害的、对钢材无腐蚀性的气体。气体内不允许有粘性物质,所含尘土及硬质颗粒物不大于 $150\text{mg}/\text{m}^3$ 。气体温度不得超过 80°C 。

通风机可制成左旋和右旋两种型式。

为便于客户安装、调试,同时供应钢结构的整体支架及减振支架。

Model 4-68 Centrifugal Ventilator may be used for the indoor ventilation in ordinary factory or in large-scale building of both air input or output. Convey air or other gas which may not self-ignite, do no harm to human body or is not corrosive to the steels. No glutinous matter is allowed in the gas. The dust or grain matter is no more than $150\text{mg}/\text{m}^3$. The gas temperature is no more than 80°C .

The ventilator may be made in the model of left revolving or right revolving.

For the convenience of customer's installation and debug, the unitary bracket and shock absorption bracket.



4-68 型离心通风机性能表

Model 4-68 Centrifugal Ventilator Datasheet

机号 No.	传动方式 Type	转速 r/min	序号 No.	流量 Capacity m ³ /h	全压 Pa	所需功率 power (KW)	电动机 motor	
							规格型号 Type	功率 power kW
2.8	A	2900	1	1131	971	0.59	Y802-2	1.1
			2	1319	971	0.65		
			3	1508	961	0.71		
			4	1696	922	0.74		
			5	1885	853	0.76		
			6	2073	765	0.77		
			7	2262	657	0.78		
		1450	1	565	245	0.07	Y801-4	0.55
			2	660	245	0.08		
			3	754	235	0.09		
			4	848	226	0.09		
			5	942	216	0.1		
			6	1037	186	0.1		
			7	1131	167	0.11		
3.15	A	2900	1	1825	1246	1.11	Y90S-2	1.5
			2	2093	1246	1.2		
			3	2362	1226	1.29		
			4	2630	1177	1.36		
			5	2899	1098	1.37		
			6	3167	981	1.38		
			7	3435	853	1.4		
		1450	1	912	314	0.14	Y801-4	0.55
			2	1047	314	0.14		
			3	1181	304	0.14		
			4	1315	294	0.16		
			5	1449	275	0.17		
			6	1583	245	0.17		
			7	1718	216	0.18		
3.55	A	2900	1	2708	1608	1.94	Y100L-2	3
			2	3092	1608	2.11		
			3	3477	1569	2.24		
			4	3861	1510	2.35		
			5	4245	1402	2.44		
			6	4629	1265	2.56		
			7	5013	1108	2.41		



丹徒风机

DAN TU FANS

机号 No.	传动方式 Type	转速 r/min	序号 No.	流量 Capacity m ³ /h	全压 Pa	所需功率 power (KW)	电动机 motor	
							规格型号 Type	功率 power kW
3.55	A	1450	1	1354	402	0.29	Y801-4	0.55
			2	1546	402	0.3		
			3	1738	392	0.32		
			4	1930	373	0.33		
			5	2122	353	0.36		
			6	2315	314	0.36		
			7	2507	275	0.38		
4	A	2900	1	3984	2069	3.34	Y112M-2	4
			2	4534	2060	3.61		
			3	5083	2010	3.83		
			4	5633	1932	4.03		
			5	6182	1795	4.18		
			6	6732	1628	4.37		
			7	7281	1432	4.44		
	A	1450	1	1992	520	0.53	Y802-4	0.75
			2	2267	510	0.56		
			3	2542	500	0.6		
			4	2816	481	0.63		
			5	3091	451	0.66		
			6	3366	402	0.65		
			7	3641	353	0.69		
4.5	A	2900	1	5790	2658	5.9	Y132S2-2	7.5
			2	6573	2628	6.34		
			3	7355	2569	6.74		
			4	8137	2462	7.07		
			5	8920	2295	7.33		
			6	9702	2069	7.59		
			7	10485	1834	7.73		
	A	1450	1	2895	667	0.9	Y90S-4	1.1
			2	3286	657	0.97		
			3	3678	638	1.02		
			4	4069	619	1.08		
			5	4460	569	1.11		
			6	4851	520	1.16		
			7	5242	461	1.19		



机号 No.	传动方式 Type	转速 r/min	序号 No.	流量 Capacity m ³ /h	全压 Pa	所需功率 power (KW)	电动机 motor	
							规格型号 Type	功率 power kW
5	A	2900	1	8050	3315	10.02	Y160M2-2	15
			2	9123	3266	10.86		
			3	10197	3187	11.53		
			4	11270	3050	12.06		
			5	12343	2844	12.49		
			6	13416	2589	13.01		
			7	14490	2305	13.25		
		1450	1	4025	824	1.42	Y100L1-4	2.2
			2	4562	814	1.53		
			3	5098	794	1.63		
			4	5635	765	1.72		
			5	6172	716	1.78		
			6	6708	647	1.83		
			7	7245	579	1.89		
6.3	D	1450	1	8320	1324	4.42	Y132S-4	5.5
			2	9393	1304	4.73		
			3	10467	1275	5.01		
			4	11540	1216	5.22		
			5	12614	1138	5.41		
			6	13687	1040	5.63		
			7	14761	922	5.69		
		960	1	5508	579	1.38	Y112M-6	2.2
			2	6219	569	1.47		
			3	6930	559	1.58		
			4	7641	530	1.63		
			5	8351	500	1.71		
			6	9062	451	1.75		
			7	9773	402	1.78		
6.3	C	2240	1	12852	3159	16.09	Y180M-2	22
			2	14511	3109	17.21		
			3	16169	3030	18.19		
			4	17828	2893	18.96		
			5	19486	2707	19.65		
			6	21144	2491	20.44		
			7	22803	2197	20.8		



丹徒风机

DAN TU FANS

机号 No.	传动方式 Type	转速 r/min	序号 No.	流量 Capacity m ³ /h	全压 Pa	所需功率 power (KW)	电动机 motor	
							规格型号 Type	功率 power kW
6.3	C	2000	1	11476	2511	11.42	Y160M2-2	15
			2	12956	2481	12.27		
			3	14437	2413	12.94		
			4	15917	2305	13.49		
			5	17398	2158	14		
			6	18879	1971	14.56		
			7	20359	1756	14.78		
		1800	1	10328	2040	8.35	Y160M1-2	11
			2	11660	2010	8.94		
			3	12993	1952	9.42		
			4	14325	1863	9.82		
			5	15658	1746	10.19		
			6	16991	1589	10.56		
			7	18324	1422	10.77		
		1600	1	9180	1608	5.85	Y132S2-2	7.5
			2	10365	1589	6.28		
			3	11550	1550	6.65		
			4	12734	1471	6.89		
			5	13918	1383	7.17		
			6	15103	1255	7.42		
			7	16287	1118	7.53		
		1400	1	8032	1236	4.1	Y132S-4	5.5
			2	9069	1216	4.39		
			3	10105	1187	4.65		
			4	11142	1128	4.82		
			5	12178	1059	5.02		
			6	13215	961	5.19		
			7	14251	863	5.31		
1250	1	7172	981	2.91	Y112M-4	4		
	2	8098	971	3.13				
	3	9024	942	3.29				
	4	9949	902	3.44				
	5	10874	843	3.57				
	6	11799	765	3.69				
	7	12724	687	3.77				



机号 No.	传动方式 Type	转速 r/min	序号 No.	流量 Capacity m ³ /h	全压 Pa	所需功率 power (KW)	电动机 motor	
							规格型号 Type	功率 power kW
6.3	C	1120	1	6426	785	2.26	Y100L2-4	3
			2	7255	775	2.42		
			3	8085	755	2.56		
			4	8913	726	2.69		
			5	9743	677	2.78		
			6	10572	618	2.88		
			7	11401	549	2.93		
		1000	1	5737	628	1.61	Y100L1-4	2.2
			2	6478	618	1.73		
			3	7218	608	1.84		
			4	7958	579	1.91		
			5	8699	540	1.97		
			6	9439	490	2.05		
			7	10179	441	2.09		
		900	1	5164	510	1.27	Y90L-4	1.5
			2	5830	500	1.35		
			3	6497	490	1.4		
			4	7163	471	1.44		
			5	7829	441	1.46		
			6	8496	402	1.51		
			7	9162	353	1.51		
		800	1	4590	402	0.89	Y90S-4	1.1
			2	5182	392	0.94		
			3	5775	383	1		
			4	6367	373	1.06		
			5	6959	343	1.08		
			6	7552	314	1.13		
			7	8144	284	1.17		



丹徒风机

DAN TU FANS

机号 No.	传动方式 Type	转速 r/min	序号 No.	流量 Capacity m ³ /h	全压 Pa	所需功率 power (KW)	电动机 motor	
							规格型号 Type	功率 power kW
8	D	1450	1	17585	2158	14.4	Y180M-4	18.5
			2	19783	2118	15.4		
			3	21982	2060	16.2		
			4	24179	1971	16.9		
			5	26378	1844	17.4		
			6	28576	1677	18		
			7	30774	1501	18.3		
		960	1	11643	942	4.3	Y132M2-6	5.5
			2	13098	932	4.7		
			3	14553	902	4.9		
			4	16009	863	5.1		
			5	17464	804	5.3		
			6	18919	736	5.5		
			7	20375	657	5.5		
		730	1	8853	549	2.1	Y132M-8	3
			2	9960	539	2.2		
			3	11067	520	2.3		
			4	12173	500	2.4		
			5	13280	471	2.5		
			6	14387	422	2.57		
			7	15403	383	2.7		
8	C	1800	1	21830	3315	28.4	Y200L2-2	37
			2	24559	3266	30.4		
			3	27288	3178	32		
			4	30016	3030	33.3		
			5	32745	2834	34.4		
			6	35474	2589	35.61		
			7	38202	2315	36.1		
		1600	1	19404	2619	19.93	Y200L1-2	30
			2	21830	2579	21.3		
			3	24256	2511	22.5		
			4	26681	2293	23.4		
			5	29108	2236	24.1		
			6	31532	2050	25.1		
			7	33958	1834	25.4		



机号 No.	传动方式 Type	转速 r/min	序号 No.	流量 Capacity m ³ /h	全压 Pa	所需功率 power (KW)	电动机 motor	
							规格型号 Type	功率 power kW
8	C	1400	1	16979	2010	13.4	Y180M-4	18.5
			2	19101	1971	14.3		
			3	21224	1922	15.1		
			4	23346	1834	15.7		
			5	25468	1716	16.2		
			6	27591	1569	16.8		
			7	29713	1402	17		
		1250	1	15159	1599	9.5	Y160L-4	15
			2	17054	1569	10.1		
			3	18949	1530	10.7		
			4	20844	1461	11.1		
			5	22739	1363	11.5		
			6	24634	1246	11.9		
			7	26528	1118	12.1		
		1120	1	13583	1285	6.8	Y160M-4	11
			2	15281	1265	7.3		
			3	16979	1226	7.7		
			4	18677	1177	8		
			5	20375	1098	8.3		
			6	22073	1000	8.6		
			7	23770	892	8.7		
		1000	1	12128	1020	5.1	Y132M-4	7.5
			2	13644	1010	5.4		
			3	15160	981	5.7		
			4	16676	932	5.9		
			5	18192	873	6.1		
			6	19708	794	6.1		
			7	21224	716	6.2		
900	1	10915	834	3.7	Y132S-4	5.5		
	2	12279	814	4				
	3	13644	794	4.2				
	4	15008	755	4.3				
	5	16373	706	4.5				
	6	17738	647	4.7				
	7	19101	579	4.8				



丹徒风机

DAN TU FANS

机号 No.	传动方式 Type	转速 r/min	序号 No.	流量 Capacity m ³ /h	全压 Pa	所需功率 power (KW)	电动机 motor	
							规格型号 Type	功率 power kW
8	C	800	1	9702	657	2.6	Y112M-4	4
			2	10915	638	2.8		
			3	12128	628	2.9		
			4	13340	598	3		
			5	14554	559	3.1		
			6	15767	510	3.3		
			7	16979	461	3.3		
		710	1	8611	520	2	Y100L2-4	3
			2	9687	510	2.1		
			3	10763	490	2.2		
			4	11840	471	2.3		
			5	12916	441	2.4		
			6	13992	402	2.5		
			7	15069	363	2.5		
		630	1	7641	402	1.4	Y100L1-4	2.2
			2	8596	402	1.5		
			3	9551	392	1.6		
			4	10506	373	1.6		
			5	11461	343	1.6		
			6	12416	314	1.7		
			7	13371	284	1.7		
10	D	1450	1	35420	3442	45.3	Y250M-4	55
			2	39713	3364	48.2		
			3	44006	3266	50.8		
			4	48299	3109	52.6		
			5	52593	2923	54.4		
			6	56886	2687	56.3		
			7	61179	2422	57		
		960	1	23450	1510	13.1	Y200L1-6	18.5
			2	26293	1481	14.1		
			3	29135	1432	14.8		
			4	31978	1363	15.3		
			5	34820	1275	15.7		
			6	37662	1177	16.3		
			7	40505	1059	16.5		



机号 No.	传动方式 Type	转速 r/min	序号 No.	流量 Capacity m ³ /h	全压 Pa	所需功率 power (KW)	电动机 motor	
							规格型号 Type	功率 power kW
10	D	730	1	17832	873	5.8	Y160L-8	7.5
			2	19993	853	6.1		
			3	22155	824	6.5		
			4	24316	785	6.7		
			5	26478	736	6.9		
			6	28639	677	7.1		
			7	30801	618	7.3		
10	C	1250	1	30534	2560	30	Y225S-4	37
			2	34235	2501	31.9		
			3	37936	2422	33.5		
			4	41637	2315	34.8		
			5	45338	2167	35.9		
			6	49040	1991	37.1		
			7	52740	1795	37.6		
		1120	1	27358	2050	21.5	Y200L-4	30
			2	30674	2010	23		
			3	33990	1942	24.1		
			4	37307	1854	25		
			5	40623	1736	25.8		
			6	43939	1599	26.7		
			7	47256	1442	27		
		1000	1	24427	1638	15.4	Y180L-4	22
			2	27388	1599	16.3		
			3	30349	1550	17.1		
			4	33310	1481	17.8		
			5	36270	1383	18.3		
			6	39233	1275	19		
			7	42192	1147	19.2		
		900	1	21984	1324	11.2	Y160L-4	15
			2	24649	1295	11.9		
			3	27314	1255	12.5		
			4	29978	1197	13		
			5	32644	1128	13.5		
			6	35308	1030	13.8		
			7	37974	932	14		



丹徒风机

DAN TU FANS

机号 No.	传动方式 Type	转速 r/min	序号 No.	流量 Capacity m ³ /h	全压 Pa	所需功率 power (KW)	电动机 motor	
							规格型号 Type	功率 power kW
10	C	800	1	19541	1049	7.87	Y160M-4	11
			2	21910	1020	8.31		
			3	24279	991	8.77		
			4	26648	942	9.07		
			5	29017	883	9.36		
			6	31385	814	9.7		
			7	33754	736	9.85		
		710	1	17343	824	5.72	Y132M-4	7.5
			2	19446	804	6.07		
			3	21548	785	6.16		
			4	23650	745	6.37		
			5	25752	696	6.55		
			6	27854	647	6.85		
			7	29956	579	6.88		
		630	1	15389	647	3.99	Y132S-4	5.5
			2	17254	638	4.27		
			3	19119	618	4.49		
			4	20985	588	4.66		
			5	22850	549	4.78		
			6	24716	510	5		
			7	26581	461	5.08		
		560	1	13679	510	2.79	Y112M-4	4
			2	15337	500	2.98		
			3	16995	490	3.17		
			4	18654	461	3.24		
			5	20311	432	3.34		
			6	21969	402	3.5		
			7	23627	363	3.57		
500	1	12214	412	2.01	Y100M-4	3		
	2	13694	402	2.14				
	3	15175	392	2.26				
	4	16655	373	2.34				
	5	18135	343	2.37				
	6	19616	314	2.44				
	7	21096	284	2.48				



机号 No.	传动方式 Type	转速 r/min	序号 No.	流量 Capacity m ³ /h	全压 Pa	所需功率 power (KW)	电动机 motor	
							规格型号 Type	功率 power kW
12.5	D	960	1	45800	2354	40.13	Y280M-6	55
			2	51353	2305	42.71		
			3	56904	2236	44.97		
			4	62456	2128	46.58		
			5	68008	2001	48.19		
			6	73559	1834	49.67		
			7	79111	1657	50.45		
		730	1	34828	1363	17.66	Y225M-8	22
			2	39050	1334	18.8		
			3	43271	1295	19.8		
			4	47492	1236	20.56		
			5	51714	1157	21.19		
			6	55936	1059	21.81		
			7	60157	961	22.25		
12.5	C	1120	1	53434	3207	65.76	Y280S-4	75
			2	59912	3138	69.99		
			3	66388	3040	73.59		
			Y280M-4	4	72865	2903	76.45	
				5	79342	2717	78.75	
				6	85819	2501	81.51	
				7	92296	2256	82.62	
		1000	1	47710	2560	46.86	Y250M-4	55
			2	53492	2501	49.8		
			3	59276	2422	52.35		
			Y280S-4	4	65058	2315	54.43	
				5	70841	2167	56.1	
				6	76624	1991	57.94	
				7	82407	1975	58.7	
		900	1	42938	2069	34.1	Y280S-6	45
			2	48144	2030	36.38		
			3	53348	1961	38.15		
			4	58552	1873	39.64		
			5	63758	1756	40.9		
			6	68962	1618	42.39		
			7	74166	1451	42.27		



丹徒风机

DAN TU FANS

机号 No.	传动方式 Type	转速 r/min	序号 No.	流量 Capacity m ³ /h	全压 Pa	所需功率 power (KW)	电动机 motor	
							规格型号 Type	功率 power kW
12.5	C	800	1	38168	1638	23.99	Y225M-6	30
			2	42794	1599	25.47		
			3	47420	1550	26.79		
			4	52046	1481	27.06		
			5	56673	1383	28.63		
			6	61300	1275	29.68		
			7	65926	1147	30.02		
		710	1	33874	1285	16.7	Y200L2-6	22
			2	37980	1265	17.89		
			3	42086	1226	18.81		
			4	46191	1167	19.48		
			5	50297	1089	20.01		
			6	54403	1000	20.67		
			7	58509	902	20.95		
		630	1	30057	1010	11.75	Y1810L-6	15
			2	33700	991	12.43		
			3	37344	961	13.09		
			4	40987	912	13.51		
			5	44630	863	14.07		
			6	48273	794	14.57		
			7	51917	706	14.55		
		560	1	26717	8004	8.24	Y160L-6	11
			2	29956	785	8.75		
			3	33194	755	9.14		
			4	36433	726	9.56		
			5	39671	677	9.81		
			6	42910	628	10.23		
			7	46148	559	10.24		
500	1	23855	638	5.8	Y160M-6	7.5		
	2	26746	628	6.25				
	3	29638	608	6.57				
	4	32529	579	6.8				
	5	35421	539	6.98				
	6	38312	500	7.28				
	7	41204	451	7.38				



机号 No.	传动方式 Type	转速 r/min	序号 No.	流量 Capacity m ³ /h	全压 Pa	所需功率 power (KW)	电动机 motor	
							规格型号 Type	功率 power kW
12.5	C	450	1	21469	520	4.47	Y132M2-6	5.5
			2	24071	510	4.76		
			3	26674	490	4.98		
			4	29276	471	5.19		
			5	31897	441	5.37		
			6	34481	402	5.49		
			7	37083	363	5.57		
		400	1	19084	412	3.14	Y132M1-6	4
			2	21397	402	3.34		
			3	23710	392	3.54		
			4	26023	373	3.66		
			5	28337	343	3.71		
			6	30650	314	3.81		
			7	32963	284	3.88		
16	B	960	1	96052	3864	142	Y355M2-6	200
			2	107694	3776	151		
			3	119337	3658	160		
			4	130980	3491	165		
			5	142623	3276	171		
			6	154265	3011	176		
			7	165908	2717	179		
		800	1	80043	2687	83	Y315M1-6	90
			2	89745	2628	88	Y315M2-6	110
			3	99448	2540	92		
			4	109150	2422	96		
			5	118852	2275	99		
			6	128554	2089	102		
			7	138257	1883	103		
		710	1	71035	2118	58	Y315S-6	75
			2	79649	2069	61		
			3	88260	2001	64		
			4	96871	1912	67		
			5	105481	1795	69		
			6	114092	1648	71		
			7	122703	1481	72		



丹徒风机

DAN TU FANS

机号 No.	传动方式 Type	转速 r/min	序号 No.	流量 Capacity m ³ /h	全压 Pa	所需功率 power (KW)	电动机 motor	
							规格型号 Type	功率 power kW
16	B	630	1	63034	1667	40	Y280M-6	55
			2	70675	1628	43		
			3	78315	1579	45		
			4	85956	1501	47		
			5	93596	1412	48		
			6	101237	1295	50		
			7	108877	1167	50		
		560	1	56030	1314	28.3	Y250M-6	37
			2	62822	1285	30		
			3	69613	1246	31.6		
			4	76405	1187	32.8		
			5	83197	1118	34		
			6	89988	1020	34.9		
			7	96780	922	35.4		
		500	1	50027	1049	20.1	Y225M-6	30
			2	56091	1030	21.5		
			3	62155	991	22.4		
			4	68219	951	23.5		
			5	74283	892	24.2		
			6	80346	814	24.8		
			7	86410	736	25.2		
		450	1	45024	853	14.7	Y200L1-6	18.5
			2	50482	834	15.7		
			3	55939	804	16.4		
			4	61397	765	17		
			5	66854	716	17.5		
			6	72312	657	18		
			7	77769	598	18.5		
400	1	40022	667	10.2	Y180L-6	15		
	2	44873	657	11				
	3	49724	638	11.6				
	4	54575	608	12				
	5	59426	569	12.4				
	6	64277	520	12.7				
	7	69128	471	12.9				



机号 No.	传动方式 Type	转速 r/min	序号 No.	流量 Capacity m ³ /h	全压 Pa	所需功率 power (KW)	电动机 motor	
							规格型号 Type	功率 power kW
16	B	355	1	35519	530	7.22	Y160L-6	11
			2	39825	520	7.71		
			3	44130	500	8.05		
			4	48435	481	8.41		
			5	52471	451	8.69		
			6	57046	412	8.92		
			7	61351	373	9.07		
		315	1	31517	412	5.2	Y160M-6	7.5
			2	35337	402	5.5		
			3	39158	392	5.8		
			4	42978	373	6		
			5	46798	353	6.3		
			6	50618	324	6.49		
			7	54439	294	6.62		
20	B	710	1	138747	3305	176	Y355M-8	220
			2	155565	3227	187		
			3	172383	3128	197		
			4	189200	2981	204		
			5	206018	2795	210		
			6	222836	2569	217		
			7	239654	2324	221		
		630	1	123113	2599	123	Y355M2-8	160
			2	138036	2540	131		
			3	152959	2462	137		
			4	167882	2354	143		
			5	182805	2207	147		
			6	197728	2030	151		
			7	212650	1824	154		
		560	1	109434	2060	86.5	Y315M3-8	110
			2	122699	2010	91.8		
			3	135964	1952	96.7		
			4	149228	1854	100		
			5	162493	1745	104		
			6	175758	1599	107		
			7	189023	1442	108		



丹徒风机

DAN TU FANS

机号 No.	传动方式 Type	转 速 r/min	序号 No.	流 量	全 压 Pa	所需功率 power (KW)	电 动 机 motor	
				Capacity m ³ /h			规 格 型 号 Type	功 率 power kW
20	B	500	1	97709	1638	61.4	Y315M2-8	75
			2	109553	1599	65.2		
			3	121396	1550	68.6		
			4	133240	1481	71.3		
			5	145083	1393	73.8		
			6	156927	1275	76		
			7	168770	1147	76.9		
		450	1	87938	1324	44.7	Y315S-8	55
			2	98597	1295	47.5		
			3	109257	1255	50		
			4	119916	1197	51.9		
			5	130575	1128	53.8		
			6	141234	1030	55.2		
			7	151893	932	56.2		
		400	1	78167	1049	31.5	Y280M-8	45
			2	87642	1030	33.6		
			3	97117	991	35.1		
			4	106592	951	36.7		
			5	116067	892	37.8		
			6	125541	814	38.8		
			7	135016	736	39.4		
		355	1	69373	824	21.9	Y250M-8	30
			2	77782	804	23.3		
			3	86191	785	24.7		
			4	94600	745	25.5		
			5	103009	696	26.2		
			6	111418	647	27.4		
			7	119827	579	27.5		
315	1	61557	647	15.3	Y225M-8	22		
	2	69018	638	16.4				
	3	76480	618	17.2				
	4	83941	588	17.9				
	5	91402	549	18.3				
	6	98864	510	19.2				
	7	106325	461	19.5				



机号 No.	传动方 式 Type	转 速 r/min	序号 No.	流 量 Capacity m ³ /h	全压 Pa	所需功率 power (KW)	电 动 机 motor	
							规 格 型 号 Type	功 率 power kW
20	B	280	1	54717	510	10.7	Y200L-8	15
			2	61349	500	11.42		
			3	67982	490	12.15		
			4	74614	461	12.43		
			5	81247	432	12.81		
			6	87879	402	13.42		
			7	94511	363	13.61		
		250	1	18855	412	7.72	Y180L-8	11
			2	54776	402	8.2		
			3	60698	392	8.68		
			4	66620	373	8.97		
			5	72542	343	9.1		
			6	78463	324	9.52		
			7	84385	284	9.65		



丹徒风机

DAN TU FANS

4-68型A传动式离心通风机外形及安装尺寸

4-68 A type transmission Shape Size & Installation Size

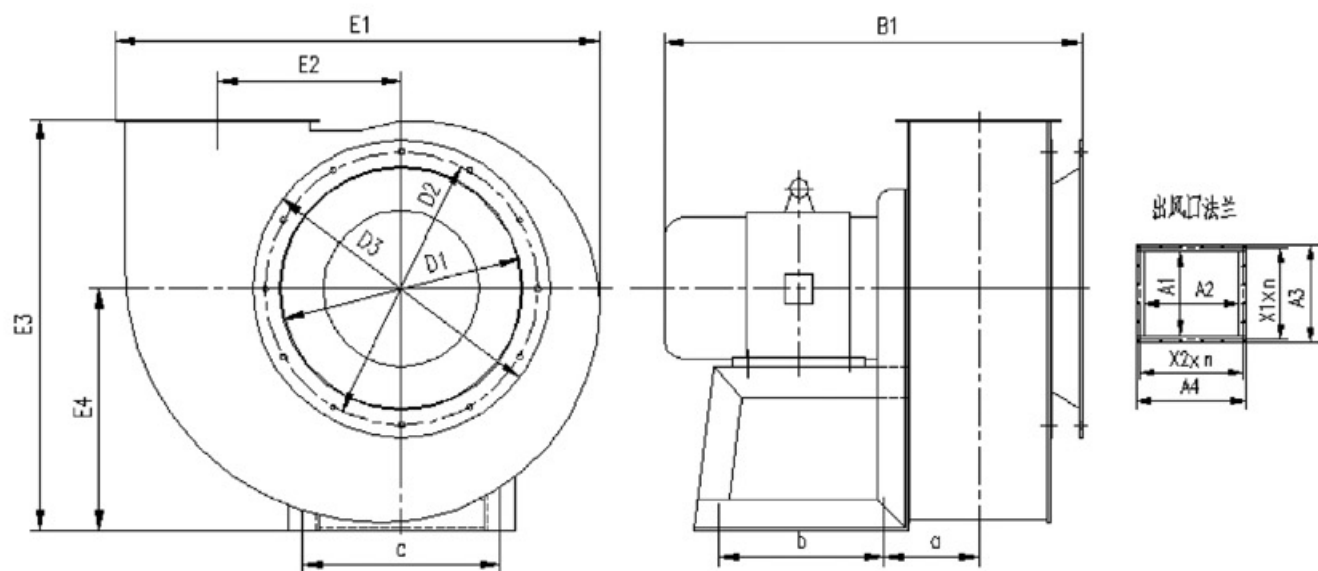

机号 No.	进风口法兰 Inlet flange						出风口法兰 Outlet flange						外形尺寸 Shape Size					安装尺寸 Installation Size					
	D1	D2	D3	联结螺栓 connecting bolt		A1	A2	A3	A4	联结螺栓 connecting bolt				E1	E2	E3	E4	B1	a	b	c	地脚螺栓孔 ground bolt slot	
				M	数量 Qty.					M	数量 Qty.	x1xn	x2xn									Φ	数量 Qty.
2.8	284	320	350	8	8	162	208	212	258	8	14	63×3	59×4	574	212	470	280	448	128.5	350	270	15	4
3.15	319	355	385	8	8	182	233	232	283	8	14	69×3	65×4	638	238.5	531	310	497	141	170	260	18	4
3.55	355	395	425	8	8	210	262	254	312	8	14	77×3	72.5×4	721	269	596	348	614	155	220	270	18	4
4	400	450	490	10	8	224	291	279	345	8	14	85×3	80.5×4	799	302	660	382	638	162	220	300	18	4
4.5	450	500	545	10	8	253	328	308	382	8	14	71×4	72×5	895	340	741	430	710	176.5	250	360	18	4
	500	560	610	10	12	289	370	339	420	8	20	63×5	66×6	994	378	842	495	858	194	340	406	18	4



4-68-6.3C、D 风机外形及安装尺寸图

4-68-6.3C、D type transmission Shape Size & Installation Size

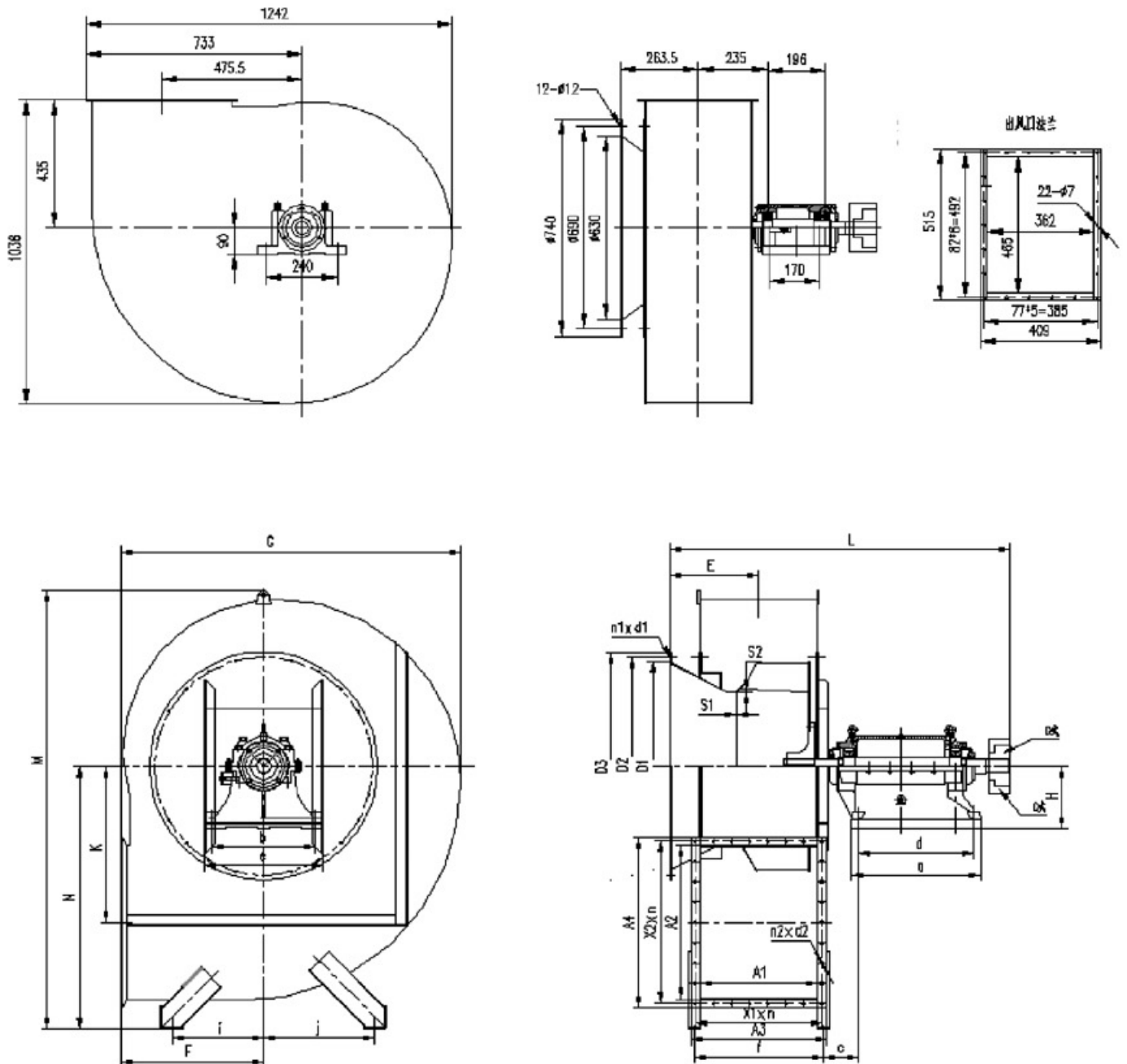



4-68 型 C、D 式传动离心通风机外形及安装尺寸

4-72 C、D type transmission Shape Size & Installation Size

机号 No.	进风口法兰 Inlet flange				出风口法兰 Outlet flange						
	D1	D2	D3	n1 × d1	A1	A2	A3	A4	n2 × d2	X1 × n	X2 × n
NO.8	800	860	910	16-15	448	592	557	698	22-12	103 × 5	109 × 6
NO.10	1000	1070	1120	16-15	560	728	669	834	22-15	125 × 5	133 × 6
NO.12.5	1250	1320	1380	20-15	700	921	810	1030	30-15	109 × 7	123 × 8

机号 No.	外形尺寸 Shape Size							基础尺寸 basis Size					
	E	F	G	K	M	H	L	a	b	c	d	e	f
NO.8	336	556	1322	605	1744	280	1530	520	440	177.5	590	510	527
NO.10	424	690	1638	756	2117	280	1675	520	440	169.5	590	510	639
NO.12.5	530	861	2053	945	2628	375	2043	700	620	209.5	780	510	780

机号 No.	各出风口方向机壳中心高及基础尺寸 Shell central height and basis size in each draught hole											
	右 0° right 0°			右 45° right 45°			右 90° right 90°			右 135° right 135°		
	N	i	j	N	i	j	N	i	j	N	i	j
NO.8	1000	400	400	890	450	400	810	450	400	750	450	400
NO.10	1220	500	550	1050	500	550	1000	550	500	930	550	500
NO.12.5	1515	660	660	1405	660	1295	1295	660	660	1200	660	660

机号 No.	各出风口方向机壳中心高及基础尺寸 Shell central height and basis size in each draught hole								
	右 180° right 180°			右 225° right 225°			S1	S2	
	N	i	j	N	i	j			
NO.8	700	450	400	650	450	400	8	0.8-2.4	
NO.10	850	550	500	790	500	550	10	1-3	
NO.12.5	1110	660	660	1035	660	660	12.5	1.3-3.8	



4-68 型 B 式传动离心通风机外形及安装尺寸

4-68 B type transmission Shape Size & Installation Size

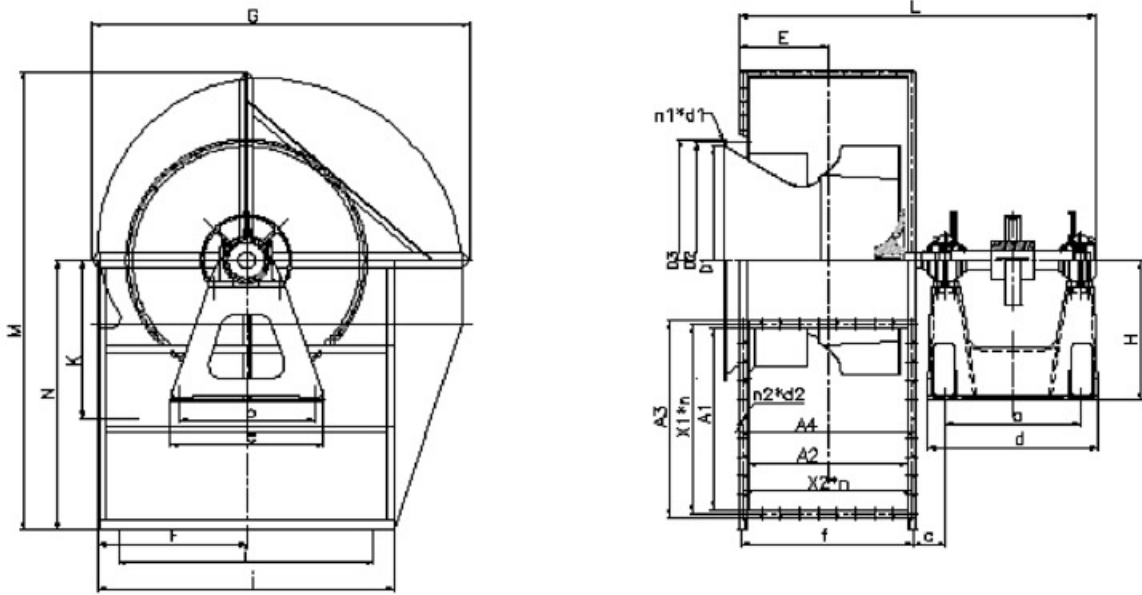

机号 No.	进风口法兰 Inlet flange				出风口法兰 Outlet flange						
	D1	D2	D3	n1 × d1	A1	A2	A3	A4	n2 × d2	X1 × n	X2 × n
NO.16	1600	1680	1750	24-19	1165	896	1274	1008	36-15	123 × 10	120 × 8
NO.20	2000	2080	2150	24-19	1456	1120	1591	1258	44-15	128 × 12	120 × 10

机号 No.	外形尺寸 Shape Size								基础尺寸 basis Size					
	E	F	G	K	N	M	H	L	a	b	c	d	e	f
NO.16	675	1080	2686	1210	1900	3245	985	2455	950	950	218.5	1200	1070	995
NO.20	845	1349	3356	1512	2350	4042	685	2723	950	950	189	1200	1070	1250

机号 No.	各出风口方向机壳中心高及基础尺寸 Shell central height and basis size in each draught hole											
	右 90° right 90°						右 180° right 180°					
	N1	i	j	M1	G1	F1	N2	i	j	M2	G2	F2
NO.16	1550	1680	2160	2630	3172	1847	1300	1680	2160	3147	2686	1080
NO.20	1950	2000	2697	3299	3963	2308	1650	2000	2697	3958	3356	1349