



丹徒风机

DAN TU FANS

4-79 型

离心通风机

Model 4-79 Centrifugal Ventilator



4-79 型离心通风机可作为一般工厂及大型建筑物的室内通风换气用, 输送空气和其他不自燃的、对人体无害的、对钢铁材料无腐蚀性的气体。气体内不允许有粘性物质, 所含尘土及硬质颗粒物不大于 $150\text{mg}/\text{m}^3$ 。气体温度不得超过 80°C 。

Model 4-79 Centrifugal Ventilator may be used for the indoor ventilation in ordinary factory or in large-scale building, conveying air or other gas which may not self-ignite, do no harm to human body or is not corrosive to the steels. No glutinous matter is allowed in the gas. The dust or grain matter is no more than $150\text{mg}/\text{m}^3$. The gas temperature is no higher than 80°C .



丹徒风机

DAN TU FANS

4-79 离心通风机性能表

Model 4-79 Centrifugal Ventilator Datasheet

机号 No.	传动 方式 Type	转 速 r/min	序号 No.	流 量 Capacity m ³ /h	全压 Pa	电 动 机 motor	
						规 格 型 号 Type	功 率 power kW
3	A	2900	1	1970	1970	Y90S-2	1.5
			2	2180	1167		
			3	2430	1157		
			4	2670	1118		
			5	2900	1069		
			6	3130	1040		
			7	3480	892		
			8	3830	726		
3	A	1450	1	990	304	Y802-4	0.75
			2	1100	294		
			3	1220	284		
			4	1340	275		
			5	1450	265		
			6	1560	255		
			7	1740	226		
			8	1910	177		
3.5	A	2900	1	3120	1628	Y100L-2	3
			2	3460	1589		
			3	3860	1569		
			4	4240	1510		
			5	4600	1461		
			6	4960	1422		
			7	5520	1206		
			8	6070	981		
3.5	A	1450	1	1560	412	Y90S-4	1.1
			2	1750	402		
			3	1930	392		
			4	2120	382		
			5	2300	363		
			6	2480	353		
			7	2760	304		
			8	3040	245		



丹徒风机

DAN TU FANS

机号 No.	传动方式 Type	转速 r/min	序号 No.	流量 Capacity m ³ /h	全压 Pa	电动机 motor	
						规格型号 Type	功率 power kW
4	A	2900	1	4670	2138	Y132S1-2	5.5
			2	5220	2079		
			3	5760	2050		
			4	6310	1981		
			5	6860	1902		
			6	7410	1853		
			7	8240	1579		
			8	9080	1275		
4	A	1450	1	2330	530	Y90S-4	1.1
			2	2610	520		
			3	2880	510		
			4	3160	490		
			5	3430	481		
			6	3710	461		
			7	4120	392		
			8	4540	324		
4.5	A	2900	1	6640	2697	Y160M1-2	11
			2	7440	2628		
			3	8200	2599		
			4	8990	2511		
			5	9790	2412		
			6	10550	2344		
			7	11720	2001		
			8	12920	1618		
4.5	A	1450	1	3320	677	Y90S-4	1.5
			2	3720	657		
			3	4110	647		
			4	4510	628		
			5	4890	598		
			6	5270	588		
			7	5860	500		
			8	6450	402		



丹徒风机

DAN TU FANS

机号 No.	传动方式 Type	转 速 r/min	序号 No.	流 量 Capacity m ³ /h	全压 Pa	电 动 机 motor	
						规 格 型 号 Type	功 率 power kW
5	A	2900	1	9100	3334	Y160M2-2	15
			2	10200	3256		
			3	11250	3217		
			4	12350	3099		
			5	13410	2981		
			6	14480	2903		
			7	16100	2471		
			8	17720	2001		
5	A	1450	1	4560	834	Y100L-1-4	2.2
			2	5100	814		
			3	5630	804		
			4	6180	775		
			5	6710	745		
			6	7240	726		
			7	8050	618		
			8	8860	500		
5.5	A	2900	1	12112	4034	Y180M-2	22
			2	13576	3940		
			3	14973	3893		
			4	16438	3750		
			5	17848	3607		
			6	19273	3513		
			7	21430	2990		
			8	23585	2421		
6	A	1450	1	7890	1196	Y132S-4	5.5
			2	8820	1177		
			3	9740	1157		
			4	10700	1118		
			5	11600	1069		
			6	12520	1040		
			7	13920	892		
			8	15320	706		
6	A	960	1	5230	530	Y100L-6	1.5
			2	5840	520		
			3	6420	510		
			4	7080	490		
			5	7680	471		
			6	8290	451		
			7	9220	402		
			8	10100	314		



丹徒风机

DAN TU FANS

机号 No.	传动 方式 Type	转 速 r/min	序号 No.	流 量 Capacity m ³ /h	全压 Pa	电 动 机 motor	
						规 格 型 号 Type	功 率 power kW
7	C	1800	1	15580	2501	Y180L-4	22
			2	17400	2461		
			3	19200	2422		
			4	21000	2334		
			5	22860	2236		
			6	24700	2177		
			7	27600	1873		
			8	30200	1481		
7	C	1600	1	13850	1971	Y160L-4	15
			2	15450	1942		
			3	17100	1912		
			4	18750	1844		
			5	20300	1765		
			6	21950	1716		
			7	24500	1481		
			8	26850	1167		
7	C	1250	1	10820	1206	Y132M-4	7.5
			2	12120	1187		
			3	13340	1167		
			4	14650	1128		
			5	15850	1079		
			6	17150	1049		
			7	19160	902		
			8	20850	716		
7	C	1120	1	9650	971	Y132S-4	5.5
			2	10830	951		
			3	11950	932		
			4	13100	902		
			5	14200	863		
			6	15350	843		
			7	17200	726		
			8	18800	549		



丹徒风机

DAN TU FANS

机号 No.	传动 方式 Type	转 速 r/min	序号 No.	流 量 Capacity m ³ /h	全压 Pa	电 动 机 motor	
						规 格 型 号 Type	功 率 power kW
7	C	1000	1	8650	775	Y112M-4	4
			2	9660	755		
			3	10660	745		
			4	11700	716		
			5	12700	686		
			6	13700	667		
			7	15300	578		
			8	16800	461		
7	C	900	1	7780	628	Y100L2-4	3
			2	8690	608		
			3	9600	598		
			4	10500	579		
			5	11400	559		
			6	12300	539		
			7	13800	471		
			8	15100	373		
7	C	800	1	6920	500	Y100L1-4	2.2
			2	7730	481		
			3	8400	471		
			4	9360	461		
			5	10160	441		
			6	10970	422		
			7	12240	373		
			8	13440	294		
7	C	710	1	6110	392	Y90L-4	1.5
			2	6850	382		
			3	7560	373		
			4	8310	363		
			5	9020	343		
			6	9730	333		
			7	10870	294		
			8	11900	235		



丹徒风机

DAN TU FANS

机号 No.	传动 方式 Type	转 速 r/min	序号 No.	流 量 Capacity m ³ /h	全压 Pa	电 动 机 motor	
						规 格 型 号 Type	功 率 power kW
8	C	1600	1	21500	2491	Y200L-4	30
			2	24000	2452		
			3	26500	2422		
			4	29200	2334		
			5	31600	2236		
			6	34200	2177		
			7	38100	1873		
			8	41700	1481		
8	C	1270	1	17100	1569	Y160L-4	15
			2	19100	1549		
			3	21050	1530		
			4	23200	1471		
			5	25100	1412		
			6	27100	1373		
			7	30200	1177		
			8	33100	932		
8	C	1120	1	15050	1226	Y160M-4	11
			2	16800	1206		
			3	18550	1187		
			4	20400	1147		
			5	22100	1098		
			6	23900	1069		
			7	26700	922		
			8	29200	726		
8	C	1000	1	13450	971	Y132M-4	7.5
			2	15000	961		
			3	16550	951		
			4	18500	912		
			5	19750	873		
			6	21400	853		
			7	23800	735		
			8	26050	579		



丹徒风机

DAN TU FANS

机号 No.	传动 方式 Type	转 速 r/min	序号 No.	流 量 Capacity m ³ /h	全压 Pa	电 动 机 motor	
						规 格 型 号 Type	功 率 power kW
8	C	900	1	12100	785	Y132S-4	5.5
			2	13500	775		
			3	14900	765		
			4	16650	735		
			5	17800	706		
			6	19250	686		
			7	21400	598		
			8	23500	471		
8	C	800	1	10760	618	Y112M-4	4
			2	12000	613		
			3	13250	608		
			4	14800	579		
			5	15800	559		
			6	17130	549		
			7	19050	471		
			8	20850	353		
8	C	710	1	9520	490	Y100L2-4	3
			2	10660	471		
			3	11750	466		
			4	13140	461		
			5	14030	441		
			6	15200	431		
			7	16900	373		
			8	18800	294		
8	C	630	1	8450	387	Y112M-6	2.2
			2	9460	382		
			3	10430	378		
			4	11670	363		
			5	12450	343		
			6	13500	333		
			7	15000	294		
			8	16450	226		



4-79型A式传动离心通风机外形及安装尺寸

4-79 A type transmission Shape Size & Installation Size

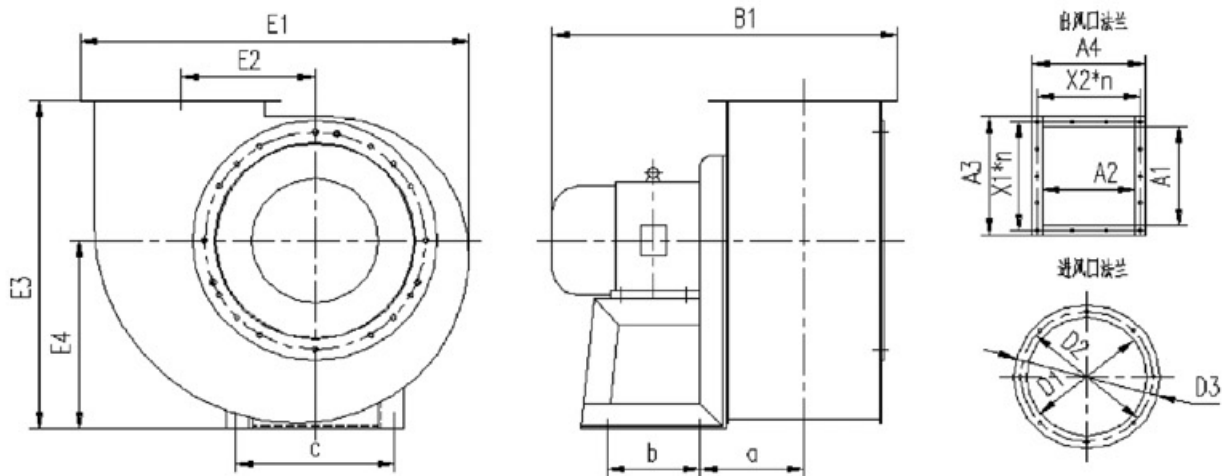

机号 No.	进风口法兰 Inlet flange					出风口法兰 Outlet flange							
	D1	D2	D3	联结螺栓 connecting bolt		A1	A2	A3	A4	联结螺栓 connecting bolt			
				M	数量 Qty.					M	数量 Qty.	x1 × n	x2 × n
3	304	335	370	8	8	254	235	304	285	8	14	70 × 4	87 × 3
3.5	350	388	420	8	8	298	277	348	327	8	12	107.7 × 3	100.7 × 3
4	404	440	486	8	8	340	312	400	372	6	18	74 × 5	86 × 4
4.5	450	490	530	8	16	382	354	462	434	8	18	84.4 × 5	98.5 × 4
5	500	550	580	8	16	426	393	506	473	8	18	94 × 5	110 × 4
5.5	550	610	640	8	16	462	432	548	512	8	18	102 × 5	119 × 4
6	600	650	680	8	16	656	478	730	548	8	22	115 × 6	102 × 5

机号 No.	外形尺寸 Shape Size					安装尺寸 Installation Size					
	E1	E2	E3	E4	B1	a	b	c	地脚螺栓孔 ground bolt slot		
									Φ	数量 Qty.	
3	588	203	506	290	523.5	157	140	240	15	4	
3.5	681	235.5	592	340	642	186.5	210	270	18	4	
4	783	272	675	387	748.5	206.5	230	340	15	4	
4.5	882	305.5	754	430	896	227	340	406	20	4	
5	981.5	340	840	480	934.5	246	340	406	20	4	
5.5	1073	373	916	520	1041	266	380	440	20	4	
6	1270	389	1090	622	919	289	250	496	18	4	



丹徒风机

DAN TU FANS

4-79型C式传动离心通风机外形及安装尺寸
4-79 C type transmission Shape Size & Installation Size

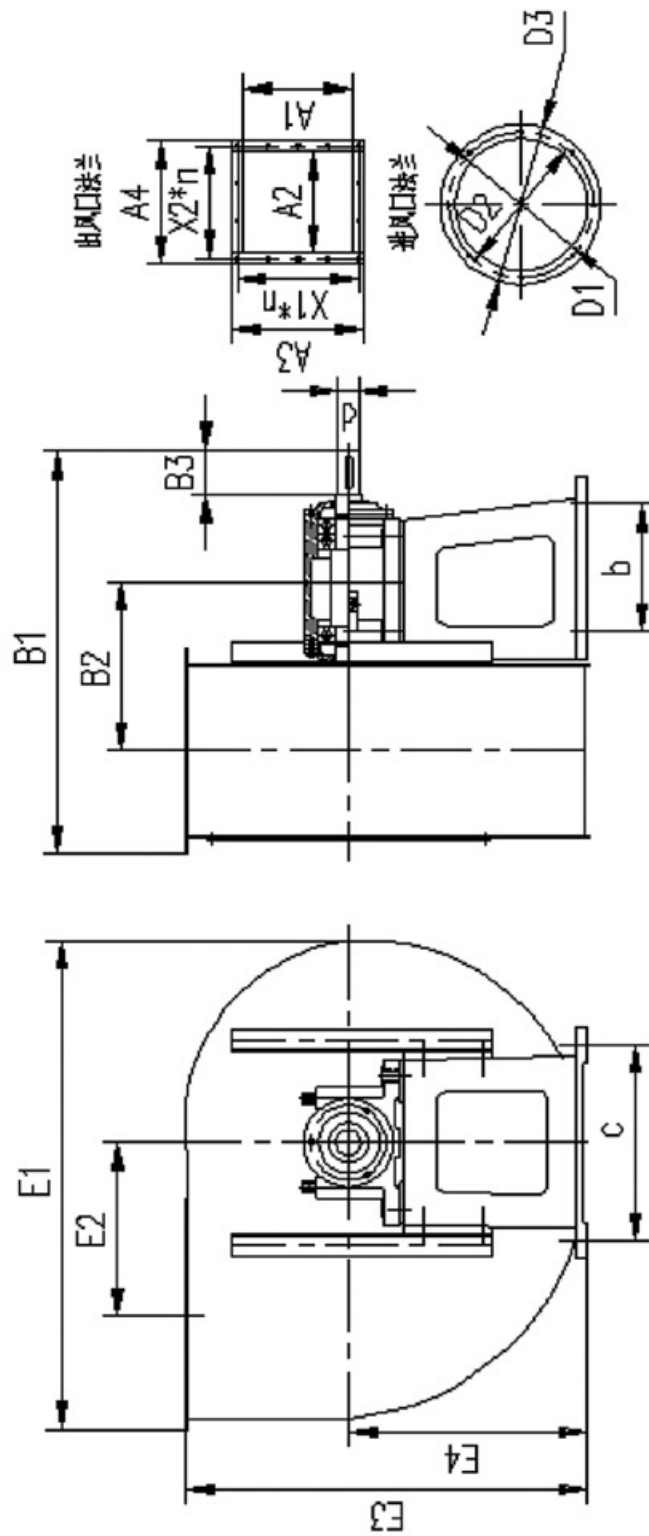



4-79型C式传动离心通风机外形及安装尺寸 4-79 C type transmission Shape Size & Installation Size

机号 No.	进风口法兰 Inlet flange				出风口法兰 Outlet flange								
	D1	D2	D3	联结螺栓 connecting bolt		A1	A2	A3	A4	联结螺栓 connecting bolt			
				M	数量 Qty.					M	数量 Qty.		
7	700	750	800	10	12	546	758	626	838	8	24	118×5	115×7
8	800	860	910	10	12	624	866	704	946	8	24	133×5	130×7

机号 No.	外形尺寸 Shape Size				安装尺寸 Installation Size					
	E1	E2	E3	E4	B1	a	b	c	地脚螺栓孔 ground bolt slot	
									Φ	数量 Qty.
7	1405	385	1270	724	1533					
8	1599	441	1450	826	1605					